

OPERATION MANUAL

DCH3200

User Guide



IMPORTANT SAFETY INSTRUCTIONS

- Read these instructions.
- Keep these instructions.
- Heed all warnings.
- Follow all instructions.
- Do not use this apparatus near water.
- The apparatus shall not be exposed to dripping or splashing and no objects filled with liquids, such as vases, shall be placed on the apparatus.
- Clean only with dry cloth.
- Do not block any ventilation openings. Install in accordance with the manufacturers instructions.
- Do not install near any heat sources such as radiators, heat registers, stoves, or other apparatus (including amplifiers) that produce heat.
- Do not defeat the safety purpose of the polarized or grounding-type plug. A polarized plug has two blades with one wider than the other. A grounding type plug has two blades and a third grounding prong. The wide blade or the third prong is provided for your safety. If the provided plug does not fit into your outlet, consult an electrician for replacement of the obsolete outlet.
- Protect the power cord from being walked on or pinched particularly at plugs, convenience receptacles, and the point where they exit from the apparatus.
- Only use attachments/accessories specified by the manufacturer.
- Unplug this apparatus during lightning storms or when unused for long periods of time.
- Refer all servicing to qualified service personnel. Servicing is required when the apparatus has been damaged in any way, such as the power-supply cord or plug is damaged, liquid has been spilled or objects have fallen into the apparatus, the apparatus has been exposed to rain or moisture, does not operate normally, or has been dropped.

IMPORTANT SAFETY CONSIDERATIONS

Be sure to follow these requirements during transportation and installation.

The plug is the mains disconnect device. It shall remain readily accessible and operable.

During Transportation to the Subscriber Home

Transport the cable terminal in its shipping box or an equally padded container.

Do not expose the terminal to rain or moisture.

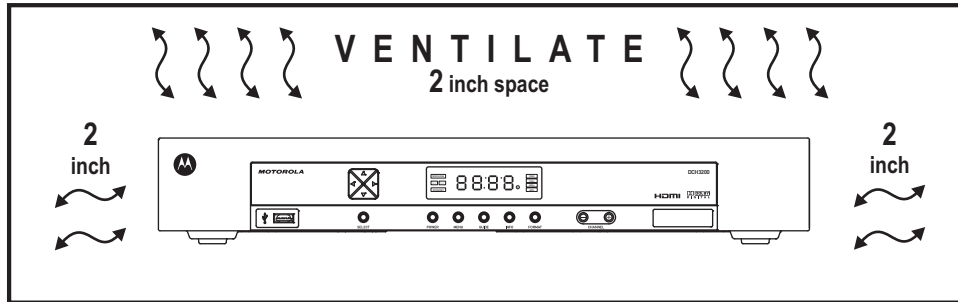

During Installation

- Do not place the cable terminal in an enclosed area where the cooling vents are blocked or impede the flow of air through the ventilation openings.
- Install the terminal so that its position does not interfere with its proper ventilation. For example, do not place the terminal on a bed, sofa, rug, or similar surface that could block the ventilation openings.
- Install the terminal away from heat sources such as radiators, heat registers and stoves. Installation of the terminal near consumer electronics devices, such as stereo receiver/amplifiers and televisions, is permitted as long as the air surrounding the terminal does not exceed 40° C (104° F).
- Place the terminal on a flat surface not prone to vibration or impact.
- Do not install the terminal in an area where condensation occurs.
- To prevent the temporary loss of guide data and cause a temporarily non-responding terminal, do not plug the AC power cord into a switched power outlet.

FCC COMPLIANCE

Note: This equipment has been tested and found to comply with the limits for a Class B digital device, pursuant to part 15 of the FCC Rules. These limits are designed to provide reasonable protection against harmful interference in a residential installation. This equipment generates uses and can radiate radio frequency energy and, if not installed and used in accordance with the instructions, may cause harmful interference to radio communications. However, there is no guarantee that interference will not occur in a particular installation. If this equipment does cause harmful interference to radio or television reception, which can be determined by turning the equipment off and on, the user is encouraged to try to correct the interference by one or more of the following measures:

- Reorient or relocate the receiving antenna.
- Increase the separation between the equipment and receiver.
- Connect the equipment into an outlet on a circuit different from that to which the receiver is connected.
- Consult the dealer or an experienced radio/TV technician for help.

Caution: Changes or modifications not expressly approved by Motorola for compliance could void the user's authority to operate the equipment.

This device complies with part 15 of the FCC Rules. Operation is subject to the following two conditions: (1) This device may not cause harmful interference, and (2) this device must accept any interference received, including interference that may cause undesired operation.

FCC DECLARATION OF CONFORMITY

Motorola Inc., Connected Home Solutions, 101 Tournament Drive, Horsham, PA 19044, 1-215-323-1000, declares that the DCH3200 receiver complies with 47 CFR Parts 2 and 15 of the FCC rules as a Class B digital device.

Canada Industry Canada (IC)

This Class B digital device complies with Canadian ICES-003.

Cet appareil numérique de la classe B est conforme à la norme NMB-003 du Canada.

CARING FOR THE ENVIRONMENT BY RECYCLING



When you see this symbol on a Motorola product, do not dispose of the product with residential or commercial waste.

Recycling your Motorola Equipment

Please do not dispose of this product with your residential or commercial waste. Some countries or regions, such as the European Union, have set up systems to collect and recycle electrical and electronic waste items. Contact your local authorities for information about practices established for your region. If collection systems are not available, call Motorola Customer Service for assistance.

Software License

IMPORTANT: PLEASE READ THIS SOFTWARE LICENSE ("LICENSE") CAREFULLY BEFORE YOU USE ANY SOFTWARE, FIRMWARE AND RELATED DOCUMENTATION ("SOFTWARE") PROVIDED WITH MOTOROLA'S DIGITAL CABLE RECEIVER OR HOME THEATER SYSTEM (EACH SHALL BE REFERRED TO IN THIS LICENSE AS A "RECEIVER"). BY USING THE RECEIVER AND/OR USING ANY OF THE SOFTWARE, YOU INDICATE YOUR ACCEPTANCE OF EACH OF THE TERMS OF THIS LICENSE. UPON ACCEPTANCE, THIS LICENSE WILL BE A LEGALLY BINDING AGREEMENT BETWEEN YOU AND MOTOROLA. THE TERMS OF THIS LICENSE APPLY TO YOU AND TO ANY SUBSEQUENT USER OF THIS SOFTWARE.

IF YOU DO NOT AGREE TO ALL OF THE TERMS OF THIS LICENSE (I) DO NOT USE THE SOFTWARE AND (II) RETURN THE RECEIVER AND THE SOFTWARE (COLLECTIVELY, "PRODUCT"), INCLUDING ALL COMPONENTS, DOCUMENTATION AND ANY OTHER MATERIALS PROVIDED WITH THE PRODUCT, TO YOUR POINT OF PURCHASE OR SERVICE PROVIDER, AS THE CASE MAY BE, FOR A FULL REFUND.

The Software includes associated media, any printed materials, and any "on-line" or electronic documentation. Software provided by third parties may be subject to separate end-user license agreements from the manufacturers of such Software. The Software is never sold. Motorola licenses the Software to the original customer and to any subsequent licensee for personal use only on the terms of this License. Motorola and its third party licensors retain the ownership of the Software.

You may:

USE the Software only in connection with the operation of the Product.

TRANSFER the Software (including all component parts and printed materials) permanently to another person, but only if the person agrees to accept all of the terms of this License. If you transfer the Software, you must at the same time transfer the Product and all copies of the Software (if applicable) to the same person or destroy any copies not transferred.

TERMINATE this License by destroying the original and all copies of the Software (if applicable) in whatever form.

You may not:

(1) Loan, distribute, rent, lease, give, sublicense or otherwise transfer the Software, in whole or in part, to any other person, except as permitted under the TRANSFER paragraph above. (2) Copy or translate the User Guide included with the Software, other than for personal use. (3) Copy, alter, translate, decompile, disassemble or reverse engineer the Software, including but not limited to, modifying the Software to make it operate on non-compatible hardware. (4) Remove, alter or cause not to be displayed, any copyright notices or startup message contained in the Software programs or documentation. (5) Export the Software or the Product components in violation of any United States export laws.

The Product is not designed or intended for use in on-line control of aircraft, air traffic, aircraft navigation or aircraft communications; or in design, construction, operation or maintenance of any nuclear facility. MOTOROLA AND ITS THIRD PARTY LICENSORS DISCLAIM ANY EXPRESS OR IMPLIED WARRANTY OF FITNESS FOR SUCH USES. YOU REPRESENT AND WARRANT THAT YOU SHALL NOT USE THE PRODUCT FOR SUCH PURPOSES.

Title to this Software, including the ownership of all copyrights, mask work rights, patents, trademarks and all other intellectual property rights subsisting in the foregoing, and all adaptations to and modifications of the foregoing shall at all times remain with Motorola and its third party licensors. Motorola retains all rights not expressly licensed under this License. The Software, including any images, graphics, photographs, animation, video, audio, music and text incorporated therein is owned by Motorola or its third party licensors and is protected by United States copyright laws and international treaty provisions. Except as otherwise expressly provided in this License, the copying, reproduction, distribution or preparation of derivative works of the Software, any portion of the Product or the documentation is strictly prohibited by such laws and treaty provisions. Nothing in this License constitutes a waiver of Motorola's rights under United States copyright law.

This License and your rights regarding any matter it addresses are governed by the laws of the Commonwealth of Pennsylvania, without reference to conflict of laws principles. THIS LICENSE SHALL TERMINATE AUTOMATICALLY if you fail to comply with the terms of this License.

Motorola is not responsible for any third party software that is provided as a bundled application, or otherwise, with the Software or that is downloaded to, or otherwise installed on, the Product.

U.S. GOVERNMENT RESTRICTED RIGHTS

The Product and documentation is provided with RESTRICTED RIGHTS. The use, duplication or disclosure by the Government is subject to restrictions as set forth in subdivision (c)(1)(ii) of The Rights in Technical Data and Computer Software clause at 52.227-7013. The contractor/manufacturer is Motorola, Inc., Connected Home Solutions, 101 Tournament Drive, Horsham, PA 19044.

© 2007 Motorola, Inc. All rights reserved. No part of this publication may be reproduced in any form or by any means or used to make any derivative work (such as translation, transformation, or adaptation) without written permission from Motorola, Inc.

MOTOROLA and the Stylized M logo are registered in the US Patent and Trademark Office. CableCARD™, M-Card™, and DOCSIS® are trademarks or registered trademarks of Cable Television Laboratories, Inc. HDMI is a trademark of HDMI Licensing LLC. Dolby is a trademark of Dolby Laboratories. Macrovision is a registered trademark of Macrovision Corporation. All other product or service names are the property of their respective owners. All rights reserved.

Motorola reserves the right to revise this publication and to make changes in content from time to time without obligation on the part of Motorola to provide notification of such revision or change. Motorola provides this guide without warranty of any kind, implied or expressed, including, but not limited to, the implied warranties of merchantability and fitness for a particular purpose. Motorola may make improvements or changes in the product(s) described in this manual at any time.



CONTENTS

1 Introduction	1
Front Panel	2
Rear Panel	3
2 Operation	5
Turning Power On and Off	5
Changing Channels	5
Adjusting the Volume	5
Interactive Program Guide	5
Front Panel Format Button	5
Operation	6
Video Format Indicators (Front Panel Display)	6
M-Card™	6
3 Connections	7
Video	7
Audio	8
4 Optimizing Your DCH Receiver For High-Definition TV	9
User Settings	10
5 On-Screen Graphics	13
6 Connecting Your DCH Receiver	15
Video Connection Options	16
Connecting Your DCH Receiver to an HDTV — Video Only	17
Connecting HDTV — Video	18
Cable In	18
Component Video (YPbPr)	18
HDMI	18
IEEE-1394	18
Connecting Your DCH Receiver to an HDTV — Audio	19
Connecting HDTV — Audio	19
Connecting Your DCH Receiver to an A/V Receiver — Audio	21
Connecting an A/V Receiver — Audio	21
Connecting Your DCH Receiver to a Stereo TV (SDTV)	23
Connecting a Stereo TV (SDTV)	23
Connecting Your DCH Receiver to a Stereo TV (SDTV) and Stereo VCR	24
Connecting a Stereo TV (SDTV) and Stereo VCR	24
Connecting Your DCH3200 to an A/V Receiver, Stereo TV (SDTV), and Stereo VCR	25
Connecting an A/V Receiver, TV, and VCR	26

CONTENTS

7 Recording Your Connections.....	27
Data Devices.....	28
Data Features.....	28
8 Troubleshooting.....	29



1 INTRODUCTION

Congratulations on receiving a Motorola DCH3200 High-Definition All-Digital Cable Receiver, one of the most advanced interactive digital cable receivers available today. Motorola has merged the extraordinary features of digital cable — the seemingly endless programming options, interactive program guides, Video on Demand (VOD), and commercial-free, CD quality music — and the incredible picture quality and sound of High-Definition TV (HDTV).

This receiver includes an “Entertainment Package” that enables a direct digital connection to consumer audio and video devices through IEEE-1394-DTV and HDMI™ interfaces.

This User Guide introduces you to the basic features, outlines important safeguards, and provides several options for integrating this component into your current entertainment system. Please take a few moments to read through this User Guide; the configuration diagrams, on-screen menu description and troubleshooting section will help you make the most of your home entertainment experience.

To determine which features of digital cable are provided in your service area, please check with your local cable operator. They will be happy to provide instructions for these optional services.

1 INTRODUCTION

Front Panel

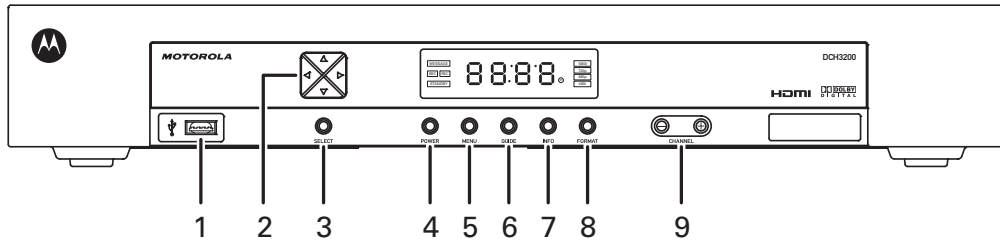

1	USB 2.0 High-Speed connector
2	Cursor — menu navigation
3	Select — selects menu options
4	Power — turns the receiver on and off (standby)
5	Menu — displays the menu
6	Guide — displays the program guide
7	Info — displays current channel and program information
8	Format * — change the video output format
9	Channel — changes channel up or down

* Availability of certain features is dependent upon application support.

1 INTRODUCTION

Rear Panel

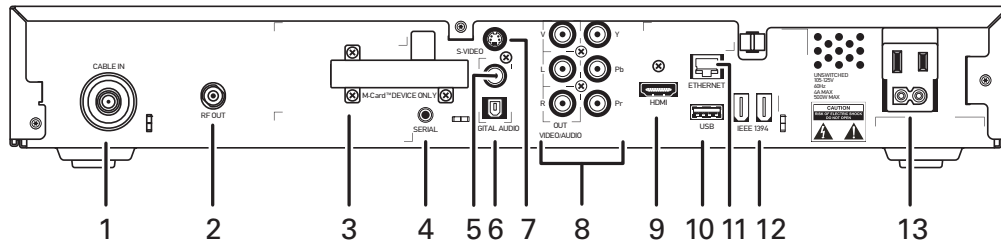

1	Cable In — Connects to cable signal from your service provider
2	RF Out — Ch 3/4 modulated audio/video (SDTV) to TV or VCR
3	M-Card — Inserted M-Card
4	Serial — Service only
5,6	Digital Audio (S/PDIF) — Provides Dolby® Digital 5.1 audio or PCM output
7	S-Video — Connects to S-Video (SDTV) input of TV or VCR
8	YPbPr — Component video output (HDTV)
8	Video/Audio Out — Composite Video (SDTV) /Audio inputs and outputs
9	HDMI — High-Definition TV (HDTV) connector
10	USB* 2.0 — High-Speed peripheral device connection
11	Ethernet* — Network connection
12	IEEE-1394 — Audio and video device connection
13	Power cord connector

* Availability of certain features is dependent upon application support.



2 OPERATION

Turning Power On and Off

Press POWER on the front panel or remote control to turn the DCH receiver on or off (standby). When using the remote control, be sure it is in cable mode by pressing CABLE before pressing POWER.

Changing Channels

You can change channels in three ways:

- Press CHANNEL + or – on the front panel of the DCH receiver or the remote control to step through the channel selection.
- Enter the number of the channel you wish to view using the number keys on the remote control.
- Select the channel in the Interactive Program Guide.

Adjusting the Volume

Press VOLUME + or – on the remote control to adjust the volume. When you adjust the volume, the volume scale is displayed on the screen. Press MUTE on the remote control to toggle the sound on and off.

For best audio quality, use the remote control to set the DCH receiver to approximately three quarters of the maximum volume level and then adjust the audio levels on external devices such as your TV or A/V receiver.

Interactive Program Guide

The Interactive Program Guide displays information about TV programs and enables you to access features such as Parental Control or Pay-Per-View. Interactive program guides can vary with each cable service provider. Refer to the Interactive Program Guide's instruction manual for detailed instructions.

Front Panel Format Button

The Format button located on the front panel of the DCH3200 allows you to quickly change the video output format on the Component Video (YPbPr) and HDMI outputs of the product. The DCH3200 is capable of providing the following video formats on the YPbPr and HDMI video outputs:

- High Definition 1080i (1920 x 1080 pixels)
- High Definition 720p (1280 x 720 pixels)
- Enhanced Definition 480p (720 x 480 pixels)
- Standard Definition 480i (720 x 480 pixels)

2 OPERATION

The Format button is intended to allow you to select a video output format that is compatible with a connected display device. Some televisions may not support all four video formats listed above. The Format button provides an easy method for selecting an output format that is compatible with your television.

Operation

The Format button is intended to complement the User Settings Menu (see [User Settings](#)). It is not intended to replace the User Settings Menu. The User Settings Menu is the preferred method of optimizing the DCH receiver to operate with your specific television.

If you cannot get a video display when the DCH receiver is connected to your television via Component Video or HDMI cables, use the Format button to select a video output format that results in a viewable picture on the display screen. Once a viewable picture is available, please use the User Settings Menu to optimize the DCH3200 display settings for your specific television.

Video Format Indicators (Front Panel Display)

The front panel display of the DCH3200 is equipped with four indicators to the right hand side of the display that are used to indicate the currently-selected video output format on the Component Video (YPbPr) and HDMI outputs. As the Format button is depressed, the front panel format indicators will change to illuminate the currently selected video output format in use by the DCH receiver.

Note: There are some scenarios where the DCH receiver does not change the video output format if the Format button is depressed. In these scenarios, the DCH3200 will flash the currently illuminated video format indicator on the front panel display. If this should occur, please use the User Settings Menu to make further changes to the video output settings of the DCH3200 receiver.

Note: Availability of certain features is dependent upon application support.

M-Card™

The M-Card is required to view cable television programs, previously recorded programs on the DVR, or interactive on-demand programs. The M-Card should not be removed.



3 CONNECTIONS

Video



Component video connection



HDMI connection



IEEE 1394 connection

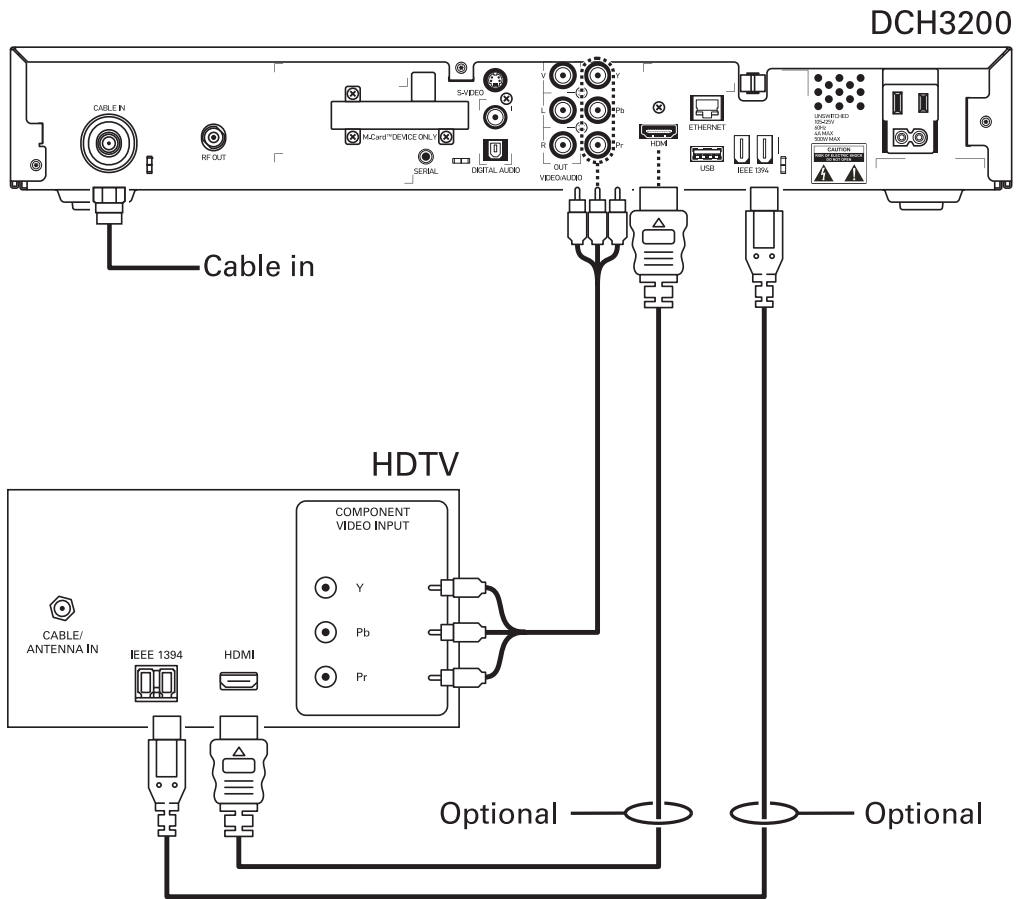

Note: Only (1) HDTV video connection needs to be made to an HDTV.

3 CONNECTIONS

Audio

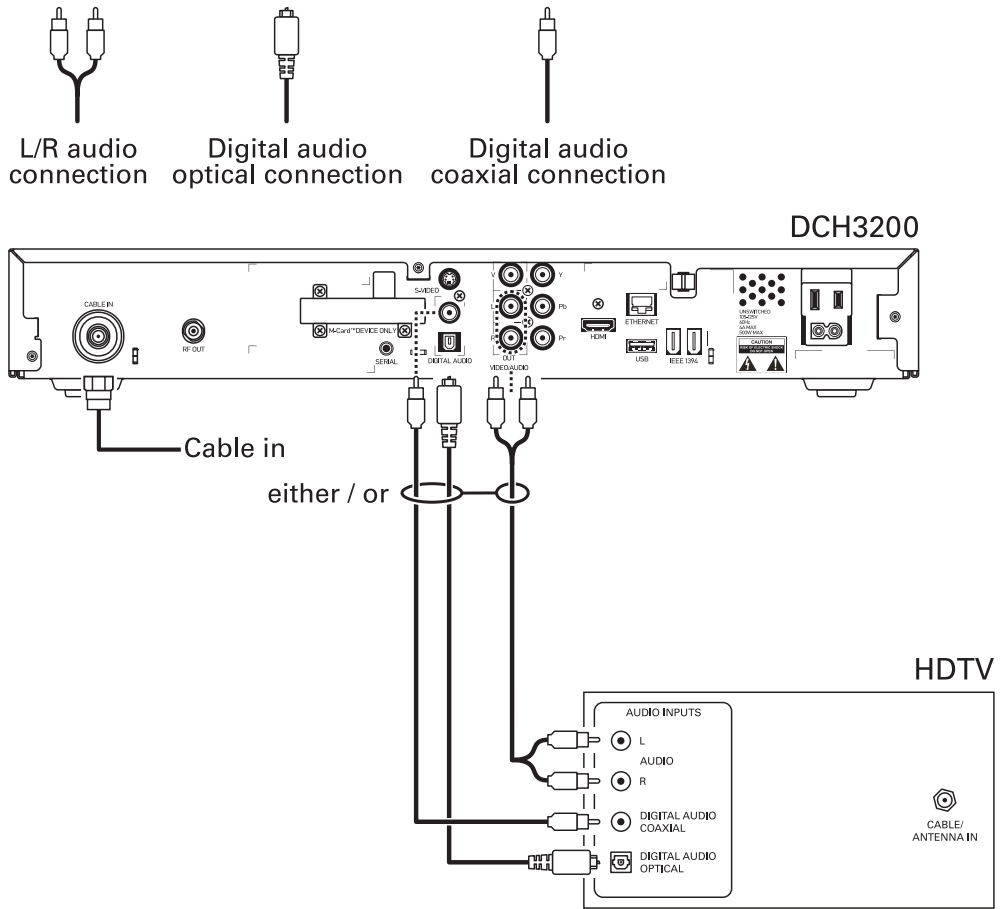

The HDMI and IEEE-1394 connections also provide audio. No additional audio connections are required if the TV speakers are used for audio.



4 OPTIMIZING YOUR DCH RECEIVER FOR HIGH-DEFINITION TV

The DCH3200 outputs HD video through its YPbPr (component), HDMI, or IEEE-1394 connectors. This section describes how to optimize standard and HD video based on your HDTV and personal preferences.

If you use the IEEE-1394 output, no adjustments to the settings are required.

For a TV with an HDMI connection, be sure the TV is on and connected to the DCH receiver HDMI out connector before adjusting the settings. Motorola recommends using HDMI cables less than 20 meters long.

You can use your on-screen menu to configure your HD settings for TV type, HDMI and/or YPbPr video output, and closed captioning.

To optimize the output settings:

1. Be sure your DCH receiver is plugged into a power outlet and connected to your TV.
2. Power off the DCH receiver and then immediately press the MENU key on the front panel. If your TV is on, the on-screen menu lists the settings you can configure:

USER SETTING STATUS	
TV TYPE:	16:9
YPbPr OUTPUT	1080i
4:3 OVERRIDE	480i
CLOSED CAPTION	DISABLED
SERVICE SELECTION	
ANALOG	CC1
DIGITAL	PRIMARY LANG
FONT SIZE	AUTO
FONT STYLE	AUTO
FONT COLOR	AUTO
FONT OPACITY	AUTO
FONT EDGE TYPE	AUTO
FONT EDGE COLOR	AUTO
BACKGROUND COLOR	AUTO
BACKGROUND OPACITY	AUTO
SETTINGS	AUTO

Use your remote control or the cursor keys on the front panel to navigate the on-screen display:

- Press the ▲ and ▼ keys to highlight the setting you wish to change. Press the ► key to select an option for that setting.
- To exit the setting and move to another setting, use the ▲ and ▼ keys.
- To exit the menu and save your settings, press the POWER or MENU key.

The HD settings are described in the table on the following pages.

4 OPTIMIZING YOUR DCH RECEIVER FOR HIGH-DEFINITION TV

The HDMI/YPbPr OUTPUT setting is displayed as YPbPr OUTPUT if you are not using the HDMI video connection. The user settings will also be displayed on the front panel display whether your TV is off or on.

If the on-screen display menu does not appear on your HDTV screen, your TV may not support the default video output setting. Use the DCH receiver front panel display to view and change your settings.

1. Use the FORMAT button to cycle video formats
2. Try an alternate video connection

User Settings

Setting	Description
TV Type	<p>Allows you to specify the style of television connected to the DCH receiver. Options include 16:9, 4:3 LETTERBOX, and 4:3 PAN SCAN. By default, the 16:9 option is selected. The options are used as follows:</p> <ul style="list-style-type: none">• 16:9 designates that a widescreen television is connected to the DCH receiver.• 4:3 LETTERBOX designates that a standard screen television is connected to the DCH receiver and that widescreen programs should be scaled to fit the screen with black bars above and below the picture.• 4:3 PAN SCAN designates that a standard screen television is connected to the DCH receiver and that widescreen programs should be cropped so that the picture fills the entire screen.
HDMI/YPbPr Output	<p>Allows you to specify the video output format of the DCH receiver for all content (when the 4:3 override setting is Off) or for all 480p, 720p, and 1080i content (when the 4:3 override is used). Options include 1080i, 720p, 480p, and 480i. By default, the 1080i option is selected. The options are used as follows:</p> <ul style="list-style-type: none">• 1080i — The DCH receiver will present programs in the High-Definition 1080i format (1920 x 1080 pixels).• 720p — The DCH receiver will present programs in the High-Definition 720p format (1280 x 720 pixels).• 480p — The DCH receiver will present programs in the Enhanced-Definition 480p format (720 x 480 pixels).• 480i — The DCH receiver will present programs in the Standard-Definition 480i format (720 x 480 pixels). <p>Some televisions may only support certain video formats. Please consult your television's user manual for more information on format compatibility.</p> <p>The DCH receiver can detect when the HDMI connection is in use. If you are not using the HDMI connection on the DCH receiver, the HDMI/YPbPr Output setting will display as YPbPr Output in the User Settings Menu.</p>
4:3 Override	<p>The 4:3 Override setting allows you to specify the video output format of the DCH receiver when it is tuned to a standard definition program. Options include 480i, 480p, Stretch, and Off. By default, the 480i option is selected. The options are used as follows:</p> <ul style="list-style-type: none">• 480i — The DCH receiver will present Standard-Definition programs in the Standard-Definition 480i format (720 x 480 pixels).• 480p — The DCH receiver will present Standard-Definition programs in the Enhanced-Definition 480p format (720 x 480

4 OPTIMIZING YOUR DCH RECEIVER FOR HIGH-DEFINITION TV

Setting	Description
	<p>pixels).</p> <ul style="list-style-type: none"> • Stretch — The DCH receiver will automatically stretch all Standard-Definition programs to a widescreen aspect ratio and present the video in the format designated by the HDMI/YPbPr Output setting. Note that the Stretch option is only available when the TV Type setting is 16:9. • Off — The DCH will create a widescreen version of a Standard-Definition program by adding black bars to the left and the right of the picture and present the video in the format designated by the HDMI/YPbPr Output setting. <p>Some televisions may only support certain video formats. Please consult your television's user manual for more information on format compatibility.</p> <p>If the HDMI/YPbPr Output setting is 480i, the 4:3 Override feature is disabled and is no longer selectable in the menu. The 4:3 Override feature is available when the HDMI/YPbPr Output setting is 1080i, 720p, or 480p.</p>
Closed Caption	Turns closed captions off or on. The front panel display indicates the status of the closed captions. Defaults to DISABLED. Options are ENABLED or DISABLED.
Service Selection	<p>Sets the service used for closed captions:</p> <ul style="list-style-type: none"> • Analog: CC1, CC2, CC3, CC4, T1, T2, T3, or T4. The default is CC1. • Digital: PRIMARY LANGUAGE, SECONDARY LANGUAGE, 3, 4, 5, or 6. The default is PRIMARY LANGUAGE.
Font Size	Sets the font size for closed captions. Defaults to AUTO. Options are AUTO, STANDARD, LARGE, or SMALL.
Font Style	Sets the font style for closed captions. Defaults to AUTO. Options are AUTO, MONO SERIF, PROPORTION SERIF, MONO NO SERIF, PROPORTION NO SERIF, CASUAL, CURSIVE, or SMALL.
Font Color	Sets the font color. Defaults to AUTO. Options are AUTO, WHITE, BLACK, RED, GREEN, BLUE, YELLOW, MAGENTA, or CYAN.
Font Opacity	Sets the opacity. Defaults to AUTO. Options are AUTO, TRANSPARENT, TRANSLUCENT, SOLID, or FLASHING.
Font Edge Type	Sets the edge appearance — AUTO, NONE, RAISED, DEPRESSED, UNIFORM, LEFT SHADOWED, or RIGHT SHADOWED. The default is AUTO.
Font Edge Color	Sets the edge color — AUTO, WHITE, BLACK, RED, GREEN, BLUE, YELLOW, MAGENTA, or CYAN. The default is AUTO.
Background Color	Sets the background color for closed captions. Defaults to AUTO. Options are AUTO, WHITE, BLACK, RED, GREEN, BLUE, YELLOW, MAGENTA, or CYAN.
Background Opacity	Sets the background opacity for closed captions. Defaults to AUTO. Options are AUTO, TRANSPARENT, TRANSLUCENT, SOLID, or FLASHING.
Settings	Sets the default settings for closed captions (AUTO) or the settings you have configured (USER). Defaults to AUTO. Options are AUTO or USER.
Restore All Defaults	To reset all User Settings to their defaults, select this option and press the ► key.

To exit the menu and save your settings, press the POWER or MENU key.



5 ON-SCREEN GRAPHICS

Your DCH receiver can generate graphics that overlay the video programming or fill the entire television screen. Common examples include on-screen menus (such as the User Setting menu), closed captions, and interactive program guides. The DCH receiver overlays these graphics whenever you open a menu, enable closed captions, or scroll through a program grid.

- On-screen graphics are not available on all video output combinations.
- On-screen graphics will not be displayed when you are using the IEEE-1394 connection on the rear panel of the DCH receiver.



6 CONNECTING YOUR DCH RECEIVER

Instructions and diagrams are included for the following connections:

- High-Definition Television (HDTV)
- A/V receiver — Audio
- Stereo TV (SDTV)
- Stereo TV (SDTV) and Stereo VCR
- A/V receiver, TV, and VCR

Before you move or change components on your entertainment system, review the following:

- For basic cable connections, use 75-ohm coaxial cables equipped with F-type connectors.
- Disconnect power from your equipment before connecting or changing cable connections.

For information on connecting to an HDTV, see “Video Connection Options” on the next page.

CAUTION!



Do not place anything on top of your DCH receiver, especially other home entertainment components. Be sure to provide adequate ventilation to prevent overheating.

6 CONNECTING YOUR DCH RECEIVER

Video Connection Options

The DCH receiver offers several different video connection options. Component video, HDMI, and IEEE-1394 allow you to view both High-Definition and Standard-Definition TV programming. Composite video, S-Video, and RF coaxial connections allow you to view only Standard-Definition TV programming.

To determine whether your TV features component video, HDMI, IEEE-1394, S-Video, or composite video, check the manual supplied with your TV.

Use the guidelines below to determine the best video connection for your home entertainment system. Note: Only (1) video connection to the TV is required. *HD video can only be viewed with HDMI, IEEE-1394, or component video connections.*

- **HDMI or IEEE-1394 — HDTV and SDTV**

HDMI and IEEE-1394 offer higher quality HD video than component video.

- If your TV has an HDMI input, this is for both audio and video. Connect an HDMI cable to the TV and to the HDMI connector on your DCH receiver.
- HDMI and IEEE-1394 outputs provide video and audio, so no separate audio connections are required if you plan to use your TV's speakers as the primary audio source.
- If your TV has a DVI input, connect a DVI-to-HDMI adapter or cable to the HDMI out connector on the DCH receiver and the DVI-HDTV connector on your TV.

DVI does not provide audio. A separate audio connection must be made.

- **Component video (YPbPr) — HDTV and SDTV**

The YPbPr connectors on your DCH receiver provide HDTV and SDTV component video.

- **S-Video — SDTV**

If a component video input is not available on your TV, use the S-Video connection.

- **Video (also referred to as composite video) — SDTV**

If an S-Video input is not available on your TV, use the composite video (video) connection.

- **RF Output — SDTV**

If no other input is available on your TV, the RF Output of the DCH6200 can be connected to the Antenna or Cable Input on your TV. The RF Output carries both video and audio. Set your TV to channel 3 or 4.

6 CONNECTING YOUR DCH RECEIVER

Connecting Your DCH Receiver to an HDTV — Video Only

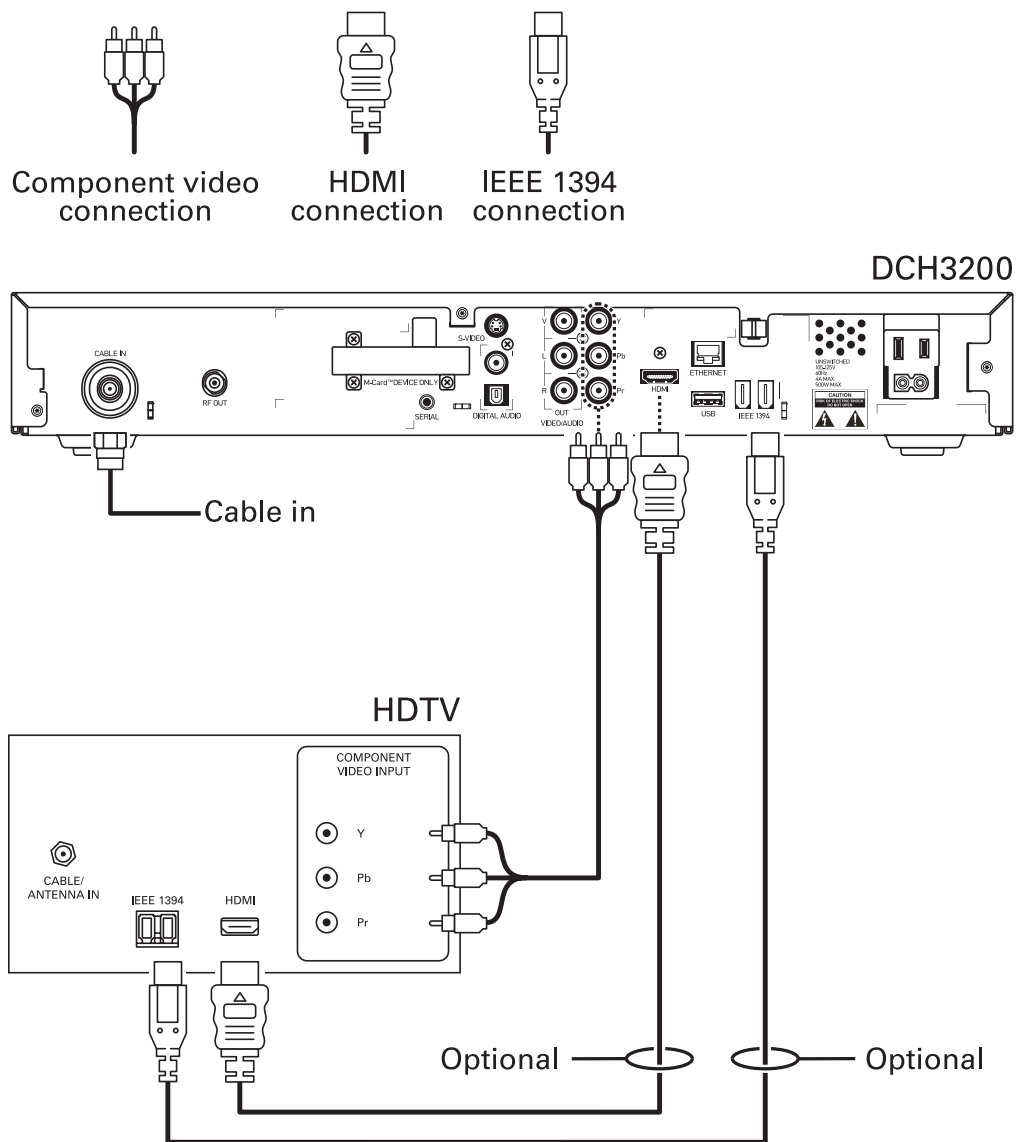

Note: Only (1) HDTV video connection needs to be made to an HDTV.

6 CONNECTING YOUR DCH RECEIVER

Connecting HDTV — Video

Cable In

Connect an RF coaxial cable to the cable wall outlet and the CABLE IN connector on the DCH receiver.

Component Video (YPbPr)

Connect the component video cables to the **Y**, **Pb**, and **Pr** connectors on your HDTV and DCH receiver.

This connection supports only the high-definition video connection between the DCH receiver and the HDTV. To connect the audio connections for your HDTV, proceed to the following page. To connect your audio connections for an A/V receiver, go to [Connecting Your DCH Receiver to an A/V Receiver — Audio](#).

Note: Be sure to match up each signal to the same connection on the TV, otherwise the colors will not appear correctly on your TV.

HDMI

If your TV has an HDMI input, this is for both audio and video if you are using the TV speakers. Connect an HDMI cable to the TV and to the HDMI connector on your DCH receiver.

If your TV has a DVI input, use the DVI connection for your video:

- Connect a DVI-to-HDMI adapter or cable to the HDMI out connector on the DCH receiver and the DVI-HDTV connector on your TV.

A DVI connection supports only the video connection between the DCH receiver and the HDTV. To connect the audio connections for your HDTV, proceed to the following page. To connect your audio connections for an A/V receiver, go to [Connecting Your DCH Receiver to an A/V Receiver — Audio](#).

If you have an audio/video receiver and are not using your TV's speakers, go to [Connecting Your DCH Receiver to an A/V Receiver — Audio](#).

DVI does not provide audio. A separate audio connection must be made.

IEEE-1394

If your HDTV has an IEEE-1394 connector, you can use the IEEE-1394 for both your video and audio connection:

- Connect an IEEE-1394 cable to the IEEE-1394 connector on your HDTV and DCH receiver.

On-screen graphics will not be displayed when you are using the IEEE-1394 connection on the rear panel of the DCH receiver.

If you have an audio/video receiver and are not using your TV's speakers, go to [Connecting Your DCH Receiver to an A/V Receiver — Audio](#).

6 CONNECTING YOUR DCH RECEIVER

Connecting Your DCH Receiver to an HDTV — Audio

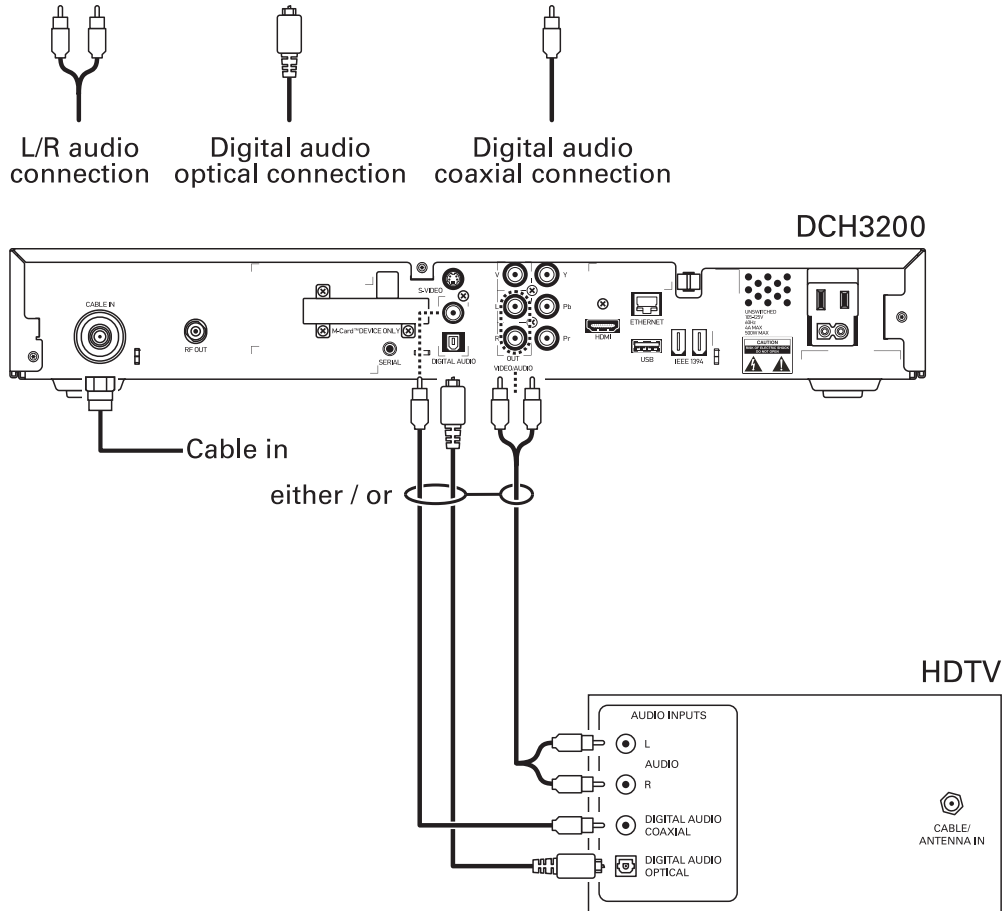

Note: Only (1) audio connection needs to be made to an HDTV.

Connecting HDTV — Audio

Note: These connections are not required if you are using your TV's speakers and HDMI or IEEE-1394 connections.

If your TV does not have digital audio inputs:

- Connect the stereo audio cable to the AUDIO L and R connectors on the DCH3200 receiver and the audio left and audio right connectors on the HDTV.

6 CONNECTING YOUR DCH RECEIVER

If your TV supports a digital audio input:

- If your equipment supports it, use the digital audio optical (S/PDIF) or coaxial (S/PDIF) outputs instead of the AUDIO L and R outputs. In most cases, S/PDIF offers better audio quality, including support for Dolby® Digital 5.1 audio.

For information on configuring your DCH receiver settings, see [Optimizing Your DCH Receiver for High-Definition TV](#).

6 CONNECTING YOUR DCH RECEIVER

Connecting Your DCH Receiver to an A/V Receiver — Audio

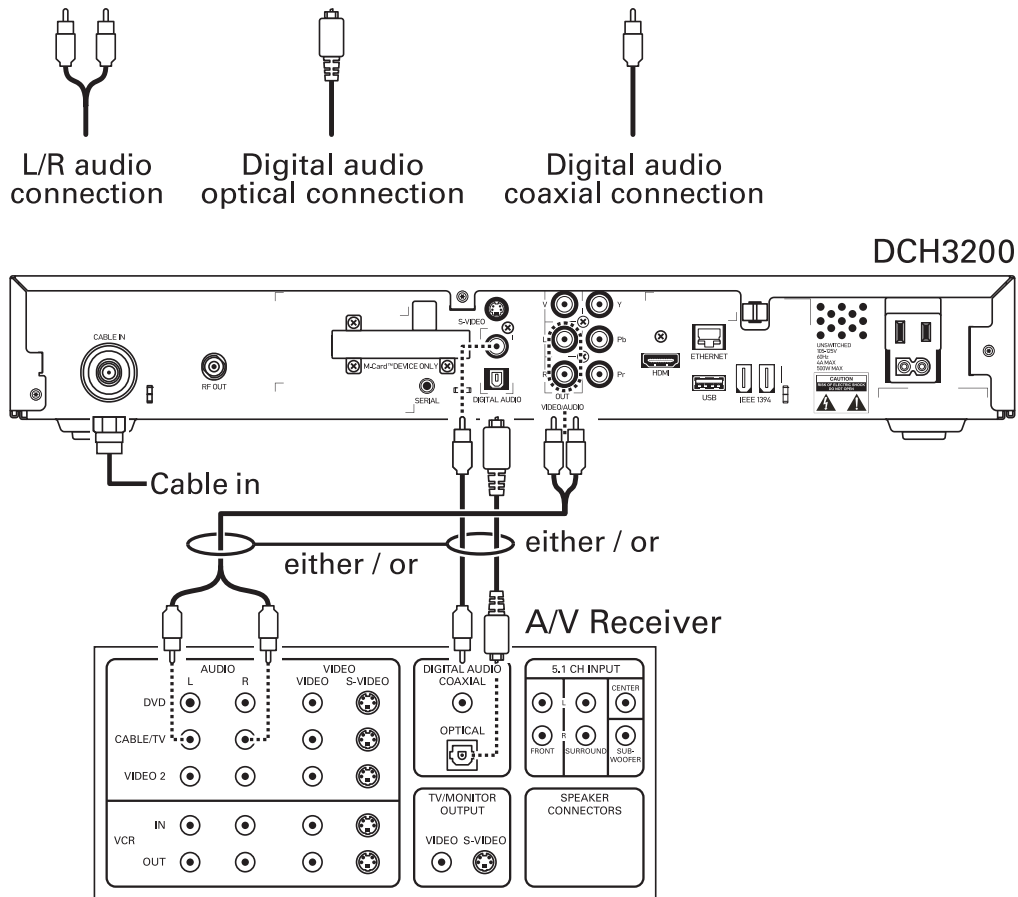

Note: Only (1) audio connection needs to be made to an A/V receiver.

Connecting an A/V Receiver — Audio

There are several options available for audio connections to your A/V receiver:

- Digital audio (OPTICAL S/PDIF)
- Digital audio (COAXIAL S/PDIF)
- Stereo audio (AUDIO L AND R)
- HDMI

If your A/V receiver supports it, the optical (S/PDIF), coaxial (S/PDIF), or HDMI audio outputs may be used in place of the stereo audio outputs (AUDIO L and R). In most cases these outputs offer a higher level of audio quality, including support for Dolby Digital 5.1 audio.

- Digital audio optical (S/PDIF) — Connect the optical cable to the digital audio optical connector on the DCH receiver and the optical connector on the A/V receiver.

6 CONNECTING YOUR DCH RECEIVER

- Digital audio coaxial (S/PDIF) — Connect the digital audio cable to the digital audio connector on the DCH receiver and the DIGITAL INPUT COAX connector on the A/V receiver.
- **Stereo audio** — Connect the stereo audio cable to the AUDIO L and R connectors on the DCH receiver and the AUDIO LEFT and AUDIO RIGHT connectors on the A/V receiver.
- **HDMI** — Connect an HDMI cable to your A/V receiver and to the HDMI connector on your DCH receiver.

For information on configuring your DCH receiver settings, see [Optimizing Your DCH Receiver for High-Definition TV](#).

6 CONNECTING YOUR DCH RECEIVER

Connecting Your DCH Receiver to a Stereo TV (SDTV)

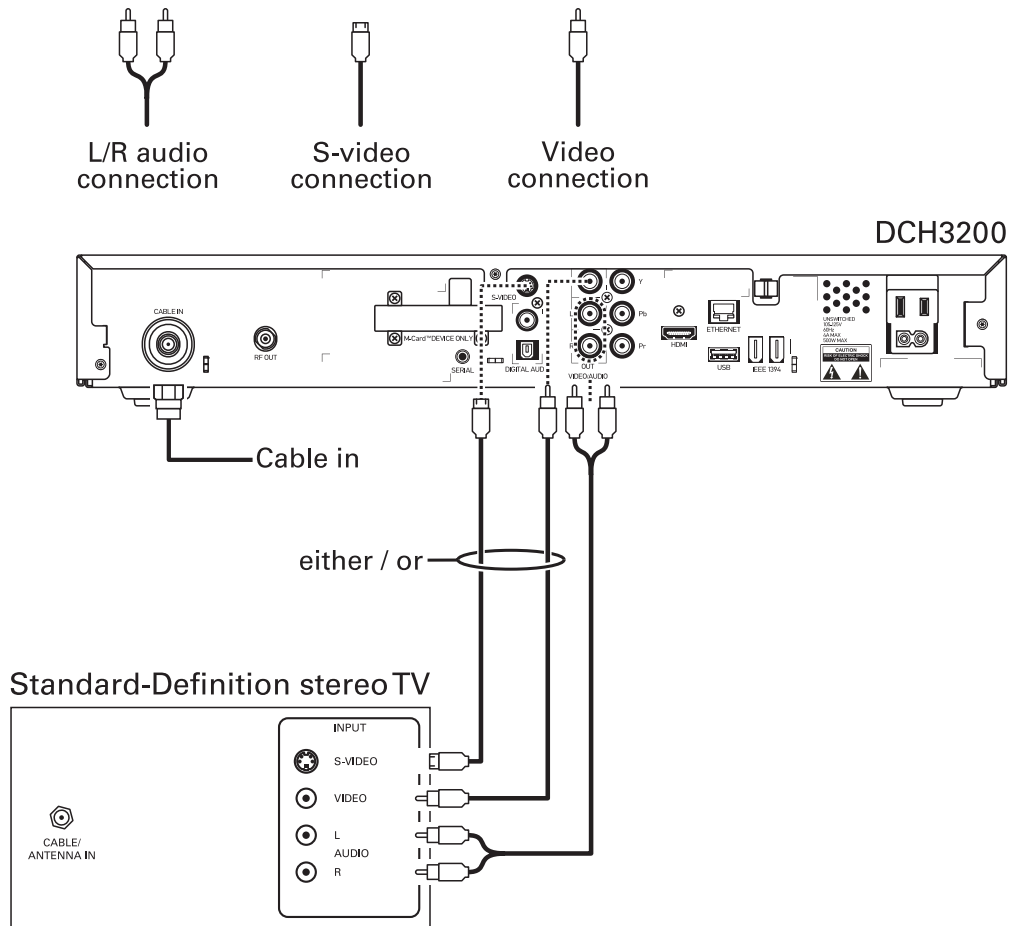

Depending on the TV's inputs:

1. If possible, use the S-Video and audio connectors on the DCH receiver.
2. If the TV has no S-Video input, use the composite video and audio connectors on the DCH receiver.
3. If the TV has an RF input only, use the RF out connector on the DCH receiver. The RF connection carries video and audio.

Connecting a Stereo TV (SDTV)

1. Connect the stereo audio cable to the AUDIO L and R connectors on the DCH receiver and the AUDIO LEFT and AUDIO RIGHT connectors on the Stereo TV (SDTV).
2. Connect a video cable to the VIDEO OUT connector on the DCH receiver and the INPUT VIDEO on the TV *or* an S-video cable to the S-VIDEO connectors on the DCH receiver and the TV.

These video connection methods do not support HD video. If you have an HDTV, see [Connecting your DCH Receiver to an HDTV – Video Only](#) on page 17.

6 CONNECTING YOUR DCH RECEIVER

Connecting Your DCH Receiver to a Stereo TV (SDTV) and Stereo VCR

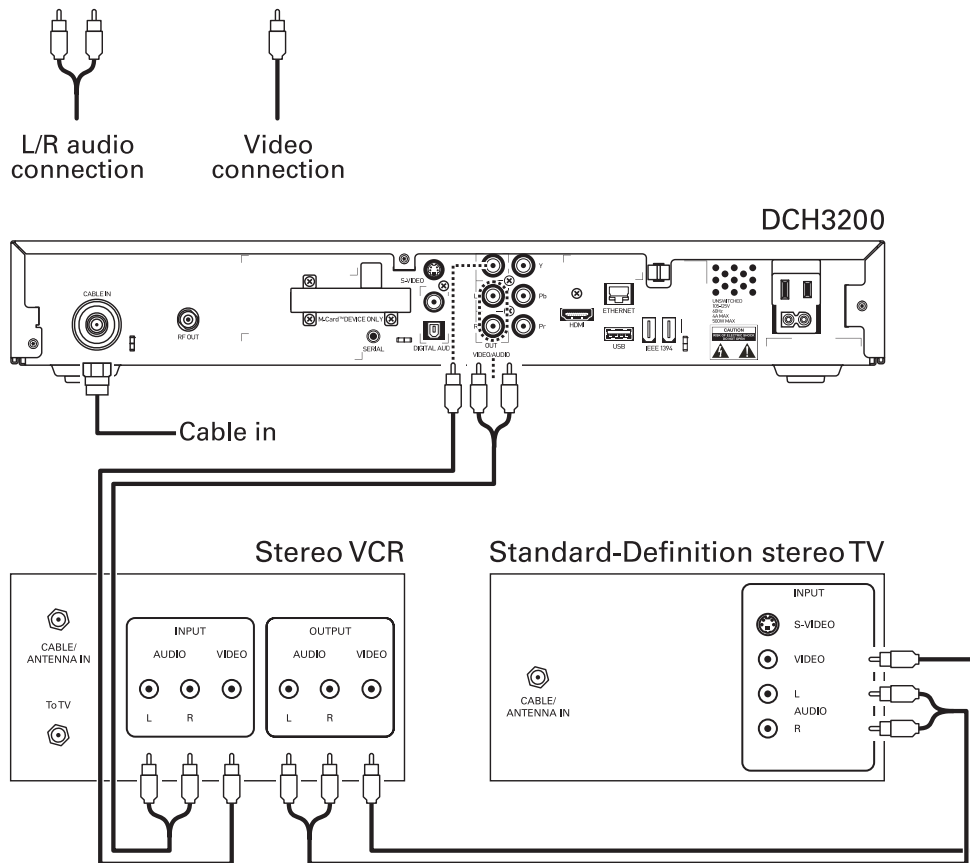

Connecting a Stereo TV (SDTV) and Stereo VCR

1. Connect a stereo audio cable to the AUDIO OUT L and R connectors on the DCH3200 receiver and the INPUT AUDIO L and R connectors on the stereo VCR.
2. Connect a video cable to the VIDEO OUT connector on the DCH3200 receiver and the INPUT VIDEO connector on the stereo VCR.
3. Connect a stereo audio cable to the OUTPUT AUDIO L and R connectors on the Stereo VCR and the INPUT AUDIO LEFT and RIGHT connectors on the Stereo TV (SDTV).
4. Connect a video cable to the output video connector on the stereo VCR and the input video connector on the Stereo TV (SDTV).

Note: You can also connect using the S-Video connectors if supported by your stereo VCR.

These video connection methods do not support HD video. If you have an HDTV, see [Connecting your DCH Receiver to an HDTV — Video Only](#) on page 17.

6 CONNECTING YOUR DCH RECEIVER

Connecting Your DCH3200 to an A/V Receiver, Stereo TV (SDTV), and Stereo VCR

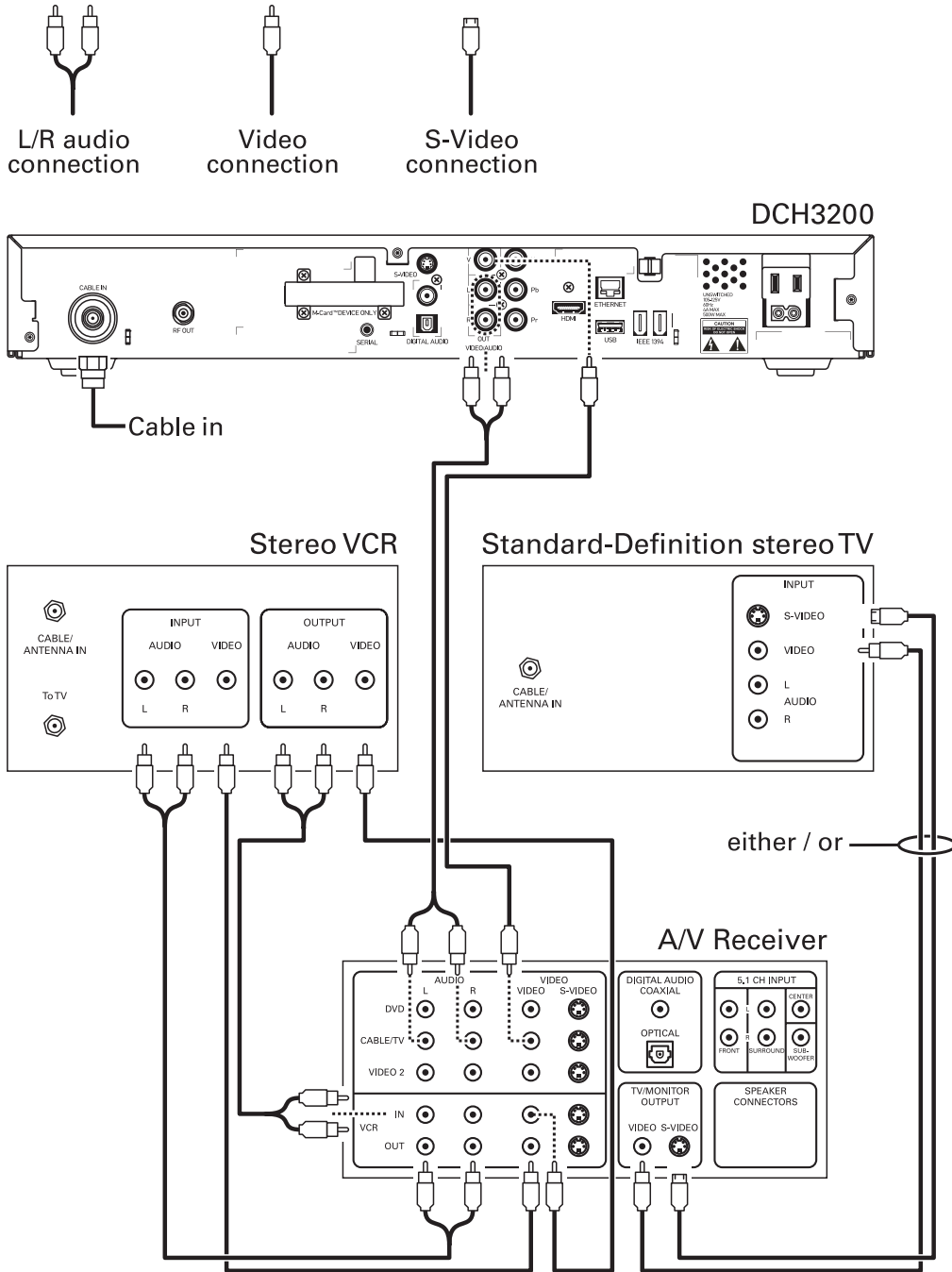

6 CONNECTING YOUR DCH RECEIVER

Connecting an A/V Receiver, TV, and VCR

1. Connect a stereo audio cable to the AUDIO OUT L and R connectors on the DCH receiver and the INPUT L and R connectors on the A/V receiver.
2. Connect a video cable to the video out connector on the DCH receiver and the cable/TV video connector on the A/V receiver.
3. Connect a stereo audio cable to the VCR AUDIO OUT L and R connectors on the A/V receiver and the INPUT AUDIO L and R connectors on the stereo VCR.
4. Connect a stereo audio cable to the OUTPUT AUDIO OUT L and R connectors on the stereo VCR and the VCR AUDIO IN L and R connectors on the A/V receiver.
5. Connect a video cable to the input video connector on the stereo VCR and the video VCR OUT connector on the A/V receiver.
6. Connect a video cable to the output video connector on the stereo VCR and the video VCR IN connector on the A/V receiver.
7. Connect a video cable to the input video connector on the Stereo TV (SDTV) and the TV/monitor output video connector on the A/V receiver.

If your equipment supports it:

- The digital audio optical (optical S/PDIF) or digital audio (COAXIAL S/PDIF) audio outputs may be used in place of the stereo audio outputs (audio l and r). In most cases these outputs offer a higher level of audio quality, including support for Dolby Digital 5.1 audio.
- S-Video connections may be used in place of the standard composite video connections. In most cases, S-Video offers a higher level of standard definition video quality than composite video.

These video connection methods do not support HD video. If you have an HDTV, see [Connecting your DCH Receiver to an HDTV – Video Only](#) on page 17.



7 RECORDING YOUR CONNECTIONS

Use this diagram to record connections between your home entertainment components. You can use this diagram to reconnect your system if you move the equipment or add new equipment.

Disconnect the power from the DCH receiver before connecting or changing cable connections. Do not place another component or object on top of the DCH receiver.

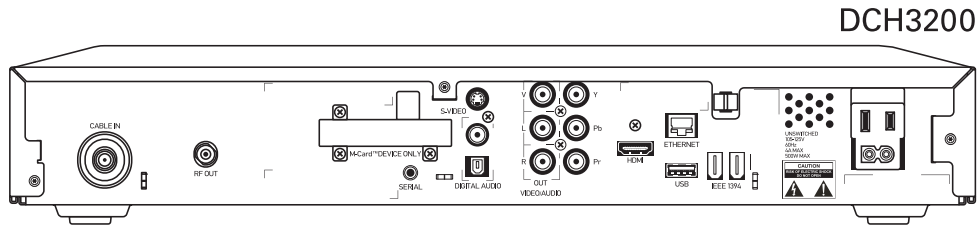

DCH3200

VCR

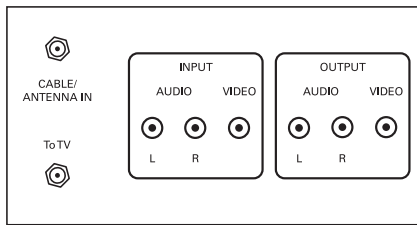

HDTV / Standard-Definition stereo TV

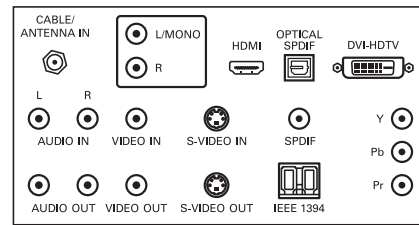

Stereo receiver

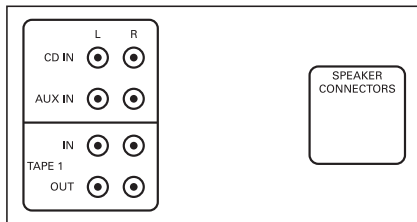

DVD

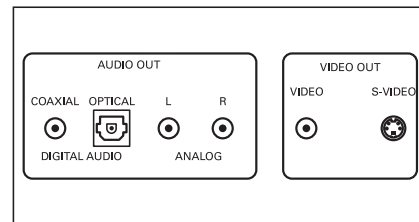

A/V receiver

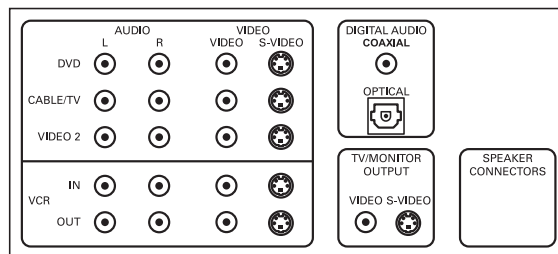

7 RECORDING YOUR CONNECTIONS

Data Devices

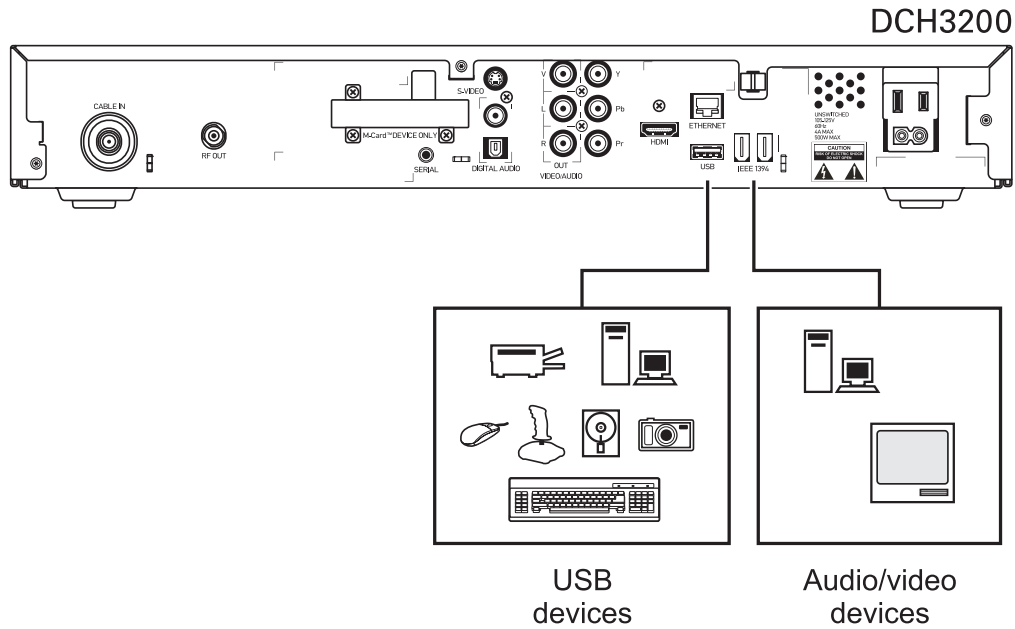

Do not attempt to connect data devices without contacting your service provider. Advanced data features require the proper application and network infrastructure to operate.

Data Features

In addition to high-quality audio and video, the DCH receiver has the capability to deliver high-speed data services such as Internet access, e-mail, IP telephony, e-commerce, and home banking.

Your DCH receiver may be equipped with the interface connections illustrated, but their functionality depends on the services offered by your service provider.



8 TROUBLESHOOTING

Before calling your service provider, review this troubleshooting guide. This information is to help you quickly solve a problem. If your problem still exists, contact your service provider.

Problem	Possible Solution
The DCH receiver will not power on	<p>The DCH receiver may have received a software update and may not power on while the new software is being installed. Try again in a few minutes.</p> <ul style="list-style-type: none"> • Verify that the AC power cord is connected to the DCH receiver and an AC outlet. Unplug the DCH receiver from the AC outlet, plug it back in, and then press the POWER button. • If the DCH receiver is connected to a switched outlet on another unit, verify that that unit is powered on. Unplug the power cord from the DCH receiver's AC outlet, plug it back in, and then press the POWER button. It is recommended to use an unswitched outlet, if possible. • Press the POWER button on the DCH receiver front panel instead of the remote control. The batteries in the remote control may be depleted.
The remote control does not work	<ul style="list-style-type: none"> • Verify that the remote control is in "Cable" mode. • Verify that there are no obstructions between the remote control and the DCH receiver. Aim the remote control directly at the DCH receiver front panel, not the TV or VCR. <p>The angle between the remote control and the DCH receiver may be too large. Stand in front of the DCH receiver and not too far to either side.</p> <ul style="list-style-type: none"> • Press and release operation keys one at a time, firmly and deliberately. • Try changing channels using the buttons on the DCH receiver front panel. • Check the batteries in the remote control. Install new batteries if needed.
There is no audio when viewing cable channels	<ul style="list-style-type: none"> • Verify that the mute button on the DCH receiver or the remote control has not been pressed. Press mute on the remote control to restore sound. • If the DCH receiver audio output is connected to the TV, verify that the mute button on the TV has not been pressed. • If the DCH receiver audio output is connected to a home theater receiver, verify that the receiver is set to the appropriate input source and the mute button on the receiver has not been pressed. • Verify that you have the correct cables for the audio connections. • Verify that the audio cables are firmly connected between the DCH receiver and the audio playback device (TV, receiver, DVD player, etc.).
There is no audio from the center and/or surround speakers of a home theater receiver connected to the DCH receiver	<p>Not all Dolby Digital® programs feature full 5.1 surround sound. In some cases, the programs may only contain left and right stereo audio.</p> <ul style="list-style-type: none"> • Verify that the S/PDIF cable (coaxial or optical) is firmly connected to the DCH receiver and the home theater receiver. • Verify that the home theater receiver is set to a surround sound

8 TROUBLESHOOTING

Problem	Possible Solution
	<p>audio mode (Dolby Digital, Dolby Pro Logic II®, Dolby Pro Logic®).</p> <ul style="list-style-type: none"> • Verify that the receiver is properly configured to work with all connected speakers.
<p>There is no video on the TV screen</p>	<ul style="list-style-type: none"> • Verify that the TV is powered on and set to the appropriate input source for the DCH receiver. • Verify that the DCH receiver is powered on and tuned to an authorized cable channel. • Verify that all video cables between the DCH receiver and the TV are firmly connected. • Verify that the coaxial cable feed is firmly connected to the DCH receiver and the wall jack. • If the DCH receiver video output is connected to a home theater unit, verify that the home theater unit is powered on and set to the appropriate input source. • If the DCH receiver video output is connected to a TV through an HDMI connection, power off the TV and then power off the DCH receiver. Wait one second and then power on the devices. <p>Not all HDTVs can display every output format (1080i, 720p, 480p, or 480i) available on the DCH receiver. To select a different format:</p> <ol style="list-style-type: none"> 1. Ensure that your DCH receiver is plugged into a power outlet and is turned off. 2. Press the MENU key on the front panel. Your settings are displayed on the DCH receiver front panel display. 3. Press the ▲ and ▼ keys to display the HDMI/YPbPr OUTPUT setting. 4. Press the ► key to cycle through the available output formats until a picture displays on the TV.
<p>No graphics or program guides appear on the TV screen</p>	<p>If you use the IEEE-1394 connection, on-screen graphics, including closed captions and program guides, are not displayed by the DCH receiver. On-screen graphics and captions may still be overlaid by your TV, if enabled. Alternatively, use HDMI or component video instead.</p>
<p>No closed captions display</p>	<ul style="list-style-type: none"> • Verify on the User Settings menu that closed captions are enabled on the DCH receiver. • Verify that closed captions are enabled on the TV. <p>Note: Closed captioning may not be available on the current program.</p>
<p>There are black bars to the right and left of the picture</p>	<p>Widescreen TVs display 4:3 programs in this format unless set to Stretch. Turn on the 4:3 OVERRIDE feature in the User Settings menu. This enables most widescreen TVs to stretch the video to fill the screen (see your TV manual for information about stretching 4:3 video).</p> <ul style="list-style-type: none"> • If the DCH3200 is connected to a widescreen TV, verify that the TV TYPE is set to 16:9 in the User Settings menu. <p>Many HD programs are broadcast in pillar-box format with black bars to the left and right of the picture. These programs are broadcast in 16:9 HD formats even though the video is not 16:9.</p>

8 TROUBLESHOOTING

Problem	Possible Solution
There are black bars above and below the picture	<p>All 4:3 HDTVs display HD programs in letterbox format (black bars above and below the picture) because of the shape of the display screen.</p> <ul style="list-style-type: none"> • Turn on the 4:3 OVERRIDE feature in the User Settings menu. This enables most standard screen TVs to display a full screen picture when the DCH3200 is tuned to a 4:3 program. • Set the TV TYPE to 4:3 Pan-Scan. This enables the DCH3200 to remove the black bars above and below the picture when possible. <p>Some SD programs are broadcast in the letterbox format with black bars above and below the picture. Some widescreen TVs offer a zoom feature that may be able to remove the black bars (see your TV manual for information about zooming 4:3 video).</p>
There are black bars on all four sides of the picture	<p>This may occur on a 4:3 TV if the 4:3 OVERRIDE setting is OFF. To set 4:3 SD programming to fill the screen, depending on the capabilities of the TV, set 4:3 OVERRIDE to 480i or 480p.</p> <p>This may occur on a 16:9 TV if the active video for an SD broadcast is in letterbox format. To confirm, wait for a commercial or look for a graphic, such as a network logo. If the commercial fills the screen from top to bottom, or the graphic appears below the active video, the program is being letterboxed by the broadcaster. You can minimize this by activating the zoom feature on the TV.</p> <p>A broadcaster may include black bars on either side of a widescreen broadcast. This is called a "hybrid" aspect ratio and results in a black border surrounding the video on a 4:3 TV. Because this is part of the broadcast, the DCH3200 cannot correct the video. You may be able to minimize the border using the zoom feature on the TV.</p>
Colors do not appear correctly	<p>Be sure to match up each signal to the same YPbPr connection on the TV, otherwise the colors will not appear correctly on your TV.</p>



MOTOROLA

Motorola, Inc.
101 Tournament Drive
Horsham, PA 19044 U.S.A.

<http://www.motorola.com>

537523-001-d
03/07